



B59

BLUELIFT

ReachMaster launched the Bluelift line in North America in 2010, and since then this line of track-based compact aerial lifts has continued to set one record after another:

The first manufacturer in the world to

- offer a 72 ft. work height unit with an overall length of less than 15 ft
- feature a true hybrid option with combined lithium and combustion engine in this class of units
- offer the most narrow units in its class
- auto centering of boom, go-home features and many more operator aid functions

The latest new feature is an innovative electro-hydraulic system that will allow the operator to use two independent functions at the same time.

With working heights from 35 – 101 ft., single and double door access combined with hybrid power solutions, the Bluelift line offers an unmatched range of versatile lifts that can be used in- and outdoor. Applications such as general rental, window cleaning, building maintenance and tree care are just a few of the many tasks where the Bluelift line will offer a superior, safer and more efficient solution.

Model	B59
Working height	59ft
Platform height	53ft
Max outreach	
● 330 lbs/basket	30ft5in
● 440 lbs/basket	26ft
● 507 lbs/basket	24ft5in
Basket dims	4ft3½in x 2ft3½in
Basket rotation	+/-90°
Turret rotation	340° non continuous
Height	6ft6in
Length (w/o basket)	12ft
Length (w/ basket)	14ft4in
Width (w/o basket)	2ft7in
Footprint	11ft X11ft
Weight (approx)	5070lbs
Max pressure, tracks	8.85 psi
Max pressure, footplate	83.90 psi
Track size (per track)	44in X 6½in
Foot pad size (per pad)	48½sq in
110V drive motor	Standard
Honda, iGX390	Standard
Hatz diesel engine	Option

We reserve the right to alterations

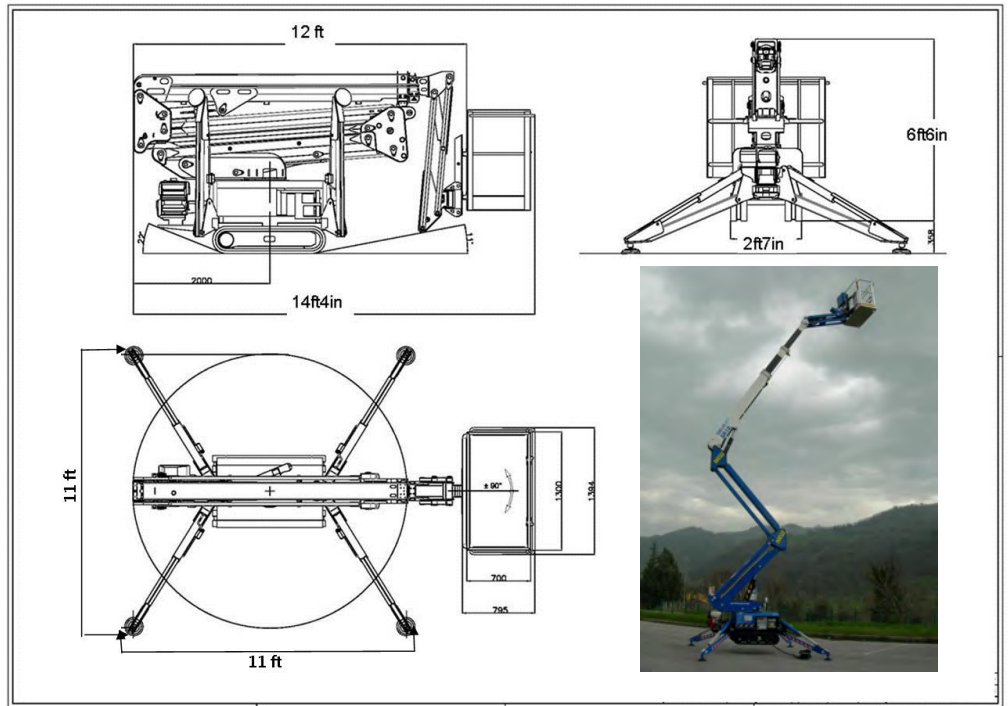
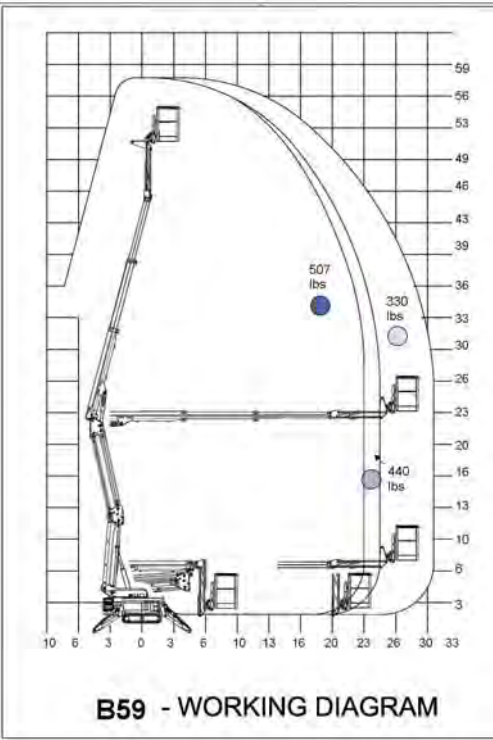

B59 BLUELIFT

Standard Specifications:

- Hydraulic Leveling platform with closed circuit
- 180° (+/-90°) basket rotation
- Protection of outrigger cylinders
- Non marking tracks
- Self propelled
- 110V drive motor
- Honda iGX390 engine
- 340° non cont. turret rotation
- Manual pump for emergency lowering
- Width of only 2ft7in
- 2 person basket

Options:

- Track width adjusting system
- Lithium battery hybrid
- Diesel engine

Additional Specifications:

- | | |
|--------------------|------------|
| Jib working angle | -100°/ 10° |
| Operating speed | 0.9mph |
| Drive gradability | 15°/28% |
| Set-up gradability | 10°/18% |

