

**Winlet**

**RUTHMANN  
REACHMASTER**

# 1320 WINLET

**Don't break your back - or the glass!**

- Lifts 1320 lbs
- Safer than manual handling
- Self propelled
- Improve job efficiency and work environment
- Access narrow doorways, elevators and balconies
- Twin wheels for rough terrain operations
- Lifts all airtight materials (glass, granite, concrete, steel, tile, fire doors, etc.)

**GOOD  
DESIGN**

2011 Winner

THE CHICAGO  
ATHENAEUM  
MUSEUM OF  
ARCHITECTURE  
AND DESIGN





### REACH DIAGRAM

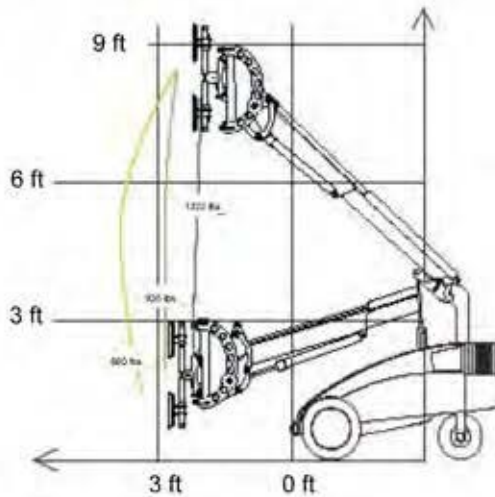

### PICKUP AND PLACE DIAGRAM

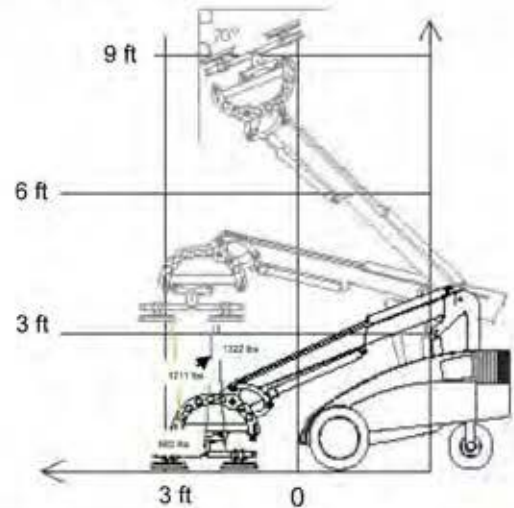

- User friendly
- Easy to transport
- Increase efficiency
- Double action safety keys
- Improve safety on jobsites
- Increase your bottom line
- Multi functional control box

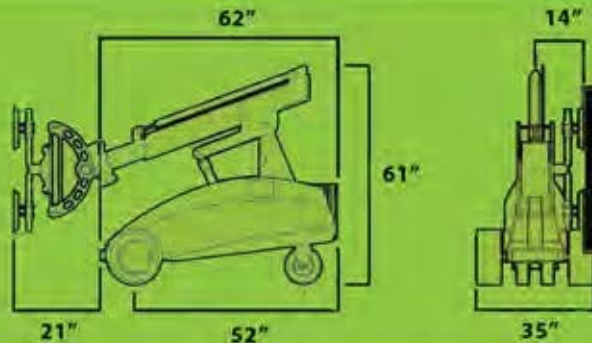

## Specifications

External Length	6'2"
External Width	2'11"
Max. Lifting Capacity	1322 lbs
Max Load @ Max Extension	660 lbs
Maximum Capacity on Side	660 lbs
Total Weight (excluding counterweight)	1905 lbs
Total Weight (including counterweight)	2335 lbs
Min. Extension (front bumper to suction cup)	2'0"
Max Extension (front bumper to suction cup)	4'3"
Max Lifting Height (to center of lifting yoke)	10'10"
Side Offset	4"
Fine Lift on Arm	8"
Tilt Function	160°
Continuous Rotation	360°
Suction cups	4 x 15"
Batteries	2 x 95 AH



## Accessories

- Twin wheels for rough terrain
- Support wheels for extra stability
- Lifting fork for pallets
- Lifting hook for straps
- Forklift Adapter



### Superior & Simple Operator Interface